



# XEFT-03EU-EGDN

Project \_\_\_\_\_

Item \_\_\_\_\_

Quantity \_\_\_\_\_

Date \_\_\_\_\_

**Model**  
BAKERLUX SHOP.Pro™ GO

Convection oven	Electric
3 trays 600x400	Drop down opening
Control panel with 7-segment display	
Manual opening	
Voltage: 220-240V 1~	

### Description

Programmable easy-to-use convection oven, ideal for baking breakfast and snack products, in particular pastry and frozen bakery ones. The digital panel allows the storage of 99 programs with 3 cooking steps plus preheating, 12 of which with immediate access. Rounded stainless steel chamber to facilitate cleaning and ensure maximum hygiene.



### Standard cooking features

#### Manual cooking

- **Temperature:** 30 °C – 260 °C
- Up to 3 cooking steps

#### Programs

- 99 Programs

### Advanced and automatic cooking features

#### Unox Intensive Cooking

- **DRY.Plus:** rapidly extracts humidity from the cooking chamber

#### Key features

- Baking chamber made of high-resistance AISI 304 stainless steel with rounded edges
- Double glass
- Baking chamber lighting through LED lights embedded in the door
- Baking chamber with chrome-plated steel rack rails



# XEFT-03EU-EGDN

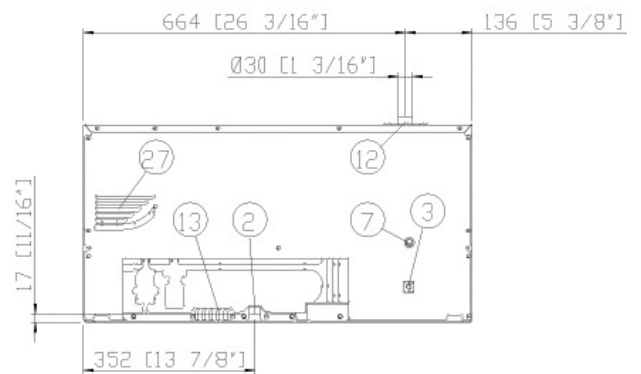
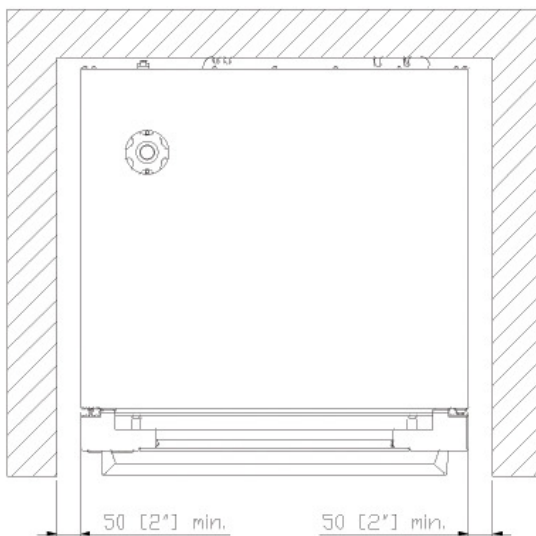
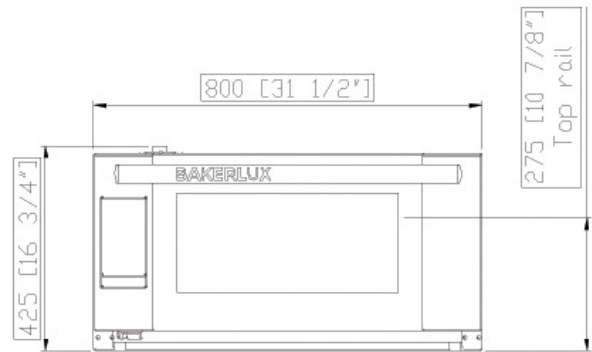
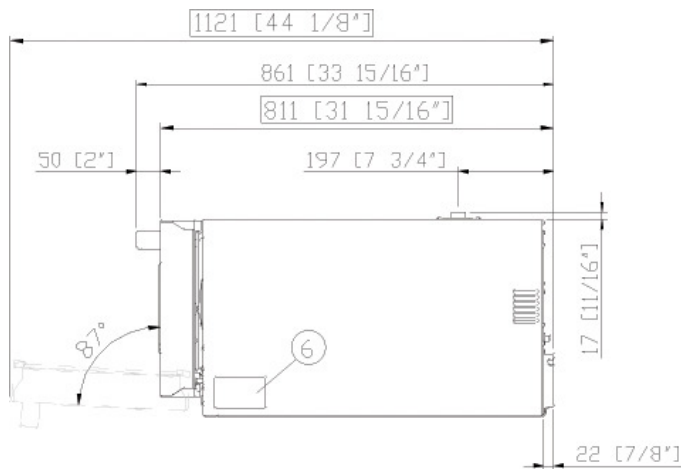

## Dimensions and weight

Width	800 mm
Depth	811 mm
Height	425 mm
Net weight	46 kg
Tray pitch	75 mm

## Connection positions

2	Terminal board power supply
3	Unipotential terminal
6	Technical data plate
7	Safety thermostat
12	Hot fumes exhaust chimney
27	Cooling air outlet



# XEFT-03EU-EGDN

Power supply

Water connection

Installation requirements

Accessories

## Electrical power supply

### STANDARD

Voltage	220-240 V
Phase	~1PH+PE
Frequency	50 / 60 Hz
Total power	3,5 kW
Max Amp draw	15 A
Required breaker size	16 A
Power cable requirements*	3G x 1,5 mm <sup>2</sup>
Plug	Schuko

\*Recommended size - observe local ordinance.

## Accessories

- **Stand:** the multifunctional support ideal for storing trays safely and placing your oven at the perfect height to work
- **Baking Essentials:** special trays
- **SPRAY&Rinse:** Practical spray detergent to manually clean all kinds of oven. It degreases and removes all kind of dirt

## Installation requirements

Installations must comply with all local electrical systems, particularly as for minimum wire gauge required for field connection, hydraulic and ventilation supply. Exhaust and fume analysis must be performed in case of gas ovens.

Register to DDC Service to access data and product specifications.  
[www.ddc.unox.com](http://www.ddc.unox.com)