

Modular Cooking Range Line EVO700 One Well Freestanding Electric Fryer 15 liter

ITEM # _____

MODEL # _____

NAME # _____

SIS # _____

AIA # _____



372081 (Z7FRED1GF0)

15-lt electric fryer with 1 "V" shape well (external heating elements) and 1 basket - free standing

Short Form Specification

Item No. _____

To be installed on height adjustable feet in stainless steel. High efficiency infrared heating elements (10KW) attached to the outside of the well. Deep drawn V-shaped well. Oil drains through a tap into a container under the well. Exterior panels in stainless steel with Scotch Brite finish. One piece pressed work top in 1.5 mm thick stainless steel. Right-angled side edges to allow flush-fitting junction between units.

Main Features

- Unit to be mounted on height adjustable feet in stainless steel.
- Deep drawn V-Shaped well.
- High efficiency infrared heating elements are attached to the outside of the well.
- Thermostatic regulation of oil temperature up to a maximum of 185 °C.
- Overheat protection thermostat as standard on all units.
- Oil drains through a tap into a drainage container positioned under the well.
- All major compartments located in front of unit for ease of maintenance.
- IPx4 water protection.
- Optional portable oil quality monitoring tool (code 9B8081) for efficient oil management.

Construction

- Interior of well with rounded corners for ease of cleaning.
- All exterior panels in Stainless Steel with Scotch Brite finishing.
- One piece pressed 1.5 mm work top in Stainless steel.
- Model has right-angled side edges to allow flush fitting joints between units, eliminating gaps and possible dirt traps.

APPROVAL: _____

Included Accessories

- 1 of Door for open base cupboard PNC 206342
- 1 of Basket for 14 and 15lt fryers PNC 921691

Optional Accessories

- Junction sealing kit PNC 206086
- Flanged feet kit PNC 206136
- Frontal kicking strip for concrete installation, 400 mm PNC 206147
- Frontal kicking strip for concrete installation, 800 mm PNC 206148
- Frontal kicking strip for concrete installation, 1000 mm PNC 206150
- Frontal kicking strip for concrete installation, 1200 mm PNC 206151
- Frontal kicking strip for concrete installation, 1600 mm PNC 206152
- Frontal handrail 400 mm PNC 206166
- Frontal handrail 800 mm PNC 206167
- Frontal kicking strip, 400 mm PNC 206175
- Frontal kicking strip, 800 mm PNC 206176
- Frontal kicking strip, 1000 mm PNC 206177
- Frontal kicking strip, 1200 mm PNC 206178
- Frontal kicking strip, 1600 mm PNC 206179
- Large handrail (portioning shelf) 400 mm PNC 206185
- Large handrail (portioning shelf) 800 mm PNC 206186
- Frontal handrail 1200 mm PNC 206191
- Frontal handrail 1600 mm PNC 206192
- 4 feet for concrete installation (not for 900 line freestanding grill) PNC 206210
- Sediment tray for 15lt fryers PNC 206235
- Right and left side handrails PNC 206240
- Pair of side kicking strips PNC 206249
- Pair of side kicking strips (concrete installation) PNC 206265
- Oil drain pipe for 15lt free standing fryer PNC 206301
- Chimney upstand, 400 mm PNC 206303
- 2 side covering panels, height 700 mm, depth 700 mm PNC 206319
- Door for open base cupboard PNC 206342
- Base support for feet or wheels - 400mm (EVO700/900) PNC 206366
- Base support for feet or wheels - 800mm (EVO700/900) PNC 206367
- Base support for feet or wheels - 1200mm (EVO700/EVO900) PNC 206368
- Base support for feet or wheels - 1600mm (EVO700/900) PNC 206369
- Rear paneling - 600mm (EVO700/900) PNC 206373
- Rear paneling - 800mm (EVO700/900) PNC 206374

- Rear paneling - 1000mm (EVO700/900) PNC 206375
- Rear paneling - 1200mm (EVO700/900) PNC 206376
- Chimney grid net, 400mm PNC 206400
- Base support for feet/wheels (600mm) PNC 206431
- Basket for 14 and 15lt fryers PNC 921691
- 2 half size baskets for 12, 14 and 15lt fryers PNC 921692
- Filter for fryer oil collection basin for 7lt, 14lt, 15lt free standing fryers PNC 921693
- Unclogging rod for 15lt fryers drainage pipe PNC 921695
- Deflector for floured products for the 15lt fryer PNC 921696

Front

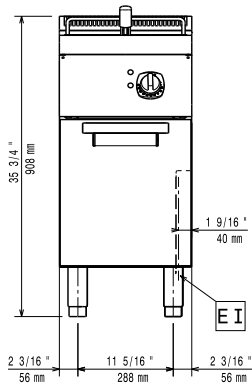

Side

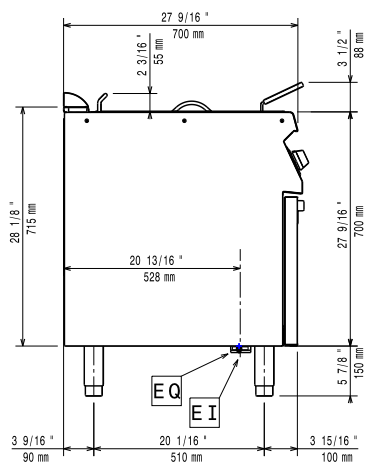

EI = Electrical inlet (power)
EQ = Equipotential screw

Top

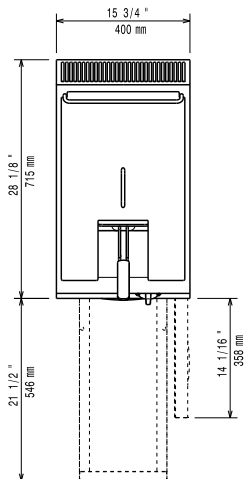

Electric

| | | |
|------------------|---------------------|--------------------------------|
| Supply voltage: | 372081 (Z7FRED1GF0) | 380-400 V/3N ph/50/60 Hz |
| Total Watts: | | 10 kW |
| Predisposed for: | | 380-400V 3N~ 50/60Hz 9-10kW |

Key Information:

| | |
|----------------------------------|------------------------|
| Usable well dimensions (width): | 240 mm |
| Usable well dimensions (height): | 505 mm |
| Usable well dimensions (depth): | 380 mm |
| Well capacity: | 13 lt MIN; 15 lt MAX |
| Thermostat Range: | 105 °C MIN; 185 °C MAX |
| Net weight: | 59 kg |
| Shipping weight: | 52 kg |
| Shipping height: | 1130 mm |
| Shipping width: | 460 mm |
| Shipping depth: | 820 mm |
| Shipping volume: | 0.43 m ³ |

If appliance is set up or next to or against temperature sensitive furniture or similar, a safety gap of approximately 150 mm should be maintained or some form of heat insulation fitted.

Certification group: N7FE1